

Operation Instructions

RC Series Single-Acting Hydraulic Cylinder

HCG Series Single-Acting High Tonnage Hydraulic Cylinder



Please read these instructions carefully before operating. And keep instructions properly for future reference.



These instructions contain warnings, precautions, operation practices, and troubleshooting for RC (HCG) series single-acting (single-acting high tonnage) hydraulic cylinder. These operation instructions are only for the reference of the end users.

I. Receiving Notice (Unpacking Inspection)

Visually inspect all components for shipping damage. Shipping damage is not covered by warranty. If shipping damage is found, notify carrier at once. The carrier is responsible for all repair and replacement costs resulting from damage in shipment.

II. Warnings and Precautions

Safety First

Please carefully read and understand the operation contents of these instructions before use and abide by these operation rules to prevent the personal injuries and equipment damages during operations of the equipment. SAIVS will not be liable for any damage arising from the incorrect operations.



Warning: Whenever possible, replace damaged or aged parts with Saivs genuine parts.



Warning: The conditions that may form backpressure for oil hoses, such as serious bending or winding of hoses and placement of objects on oil hoses, are prohibited during operations, in order to prevent burst of oil hoses from causing damages.



Warning: It's prohibited to drag or hoist other hydraulic parts (such as pump, hydraulic wrench, cylinder, and valve) by oil hoses.



Warning: During the operations, do not offset the load or overload, in order to prevent damaging cylinder and causing danger. Under loaded condition, never disassemble the quick couplings, in order to prevent causing accidents and damaging parts.



Warning: This pump utilizes the hydraulic oil as the medium. Therefore, fulfill the maintenances for the oil and this pump, in order to prevent oil silting and leakage and impair the operating performance.



Notice: For a new or long-term unused cylinder, due to excessive air content in the cylinder, the piston rod may have slight bouncing symptom at the start of operations. In such case, reciprocate the oil cylinder under no-load condition for 2~3 times to bleed the

air from the chambers. As the seals are vulnerable to aging under long-term non-use condition for a long-term unused oil cylinder to impair the service life of oil cylinder, during long-term non-use, reciprocate the oil cylinder for 2~3 times under non-load condition once a month.



Warning: The high pressure oil hoses passed the 105MPa (1050Kgf/cm²) test before delivery. However, the hoses are vulnerable to aging, the user shall check frequently, once every 6 months generally or once every 3 months under frequent condition. During the checking, test by 87.5Mpa (875kgf/cm²) pressure. Upon detection of burst, bulge, or leakage, timely replace.



Warning: During operations, strictly abide by the technical specification. The user shall fulfill the periodic checking and maintenance depending on working condition.



Notice: SAIVS will not be liable for any damages arising from incorrect operations.

III. Overview

RC (HCG) series single-acting (single-acting high tonnage) hydraulic cylinder is a kind of hydraulic tool with high-tonnage spring return function. Working together with super-pressure electric pump station or hand pump, it can realize the stretching, clamping, and correction functions in addition to the basic operations, including lifting, pushing, expanding, and squeezing. Besides the characteristics of common hydraulic cylinder, it also embodies the spring reset function to better simplify the operations and remarkably improve the working efficiency. However, the HCG series is fitted with gravity return function. At present, it's extensively applied in the infrastructures, including architecture, ship, mining, petrochemical industry, and railway.

IV. Model Description

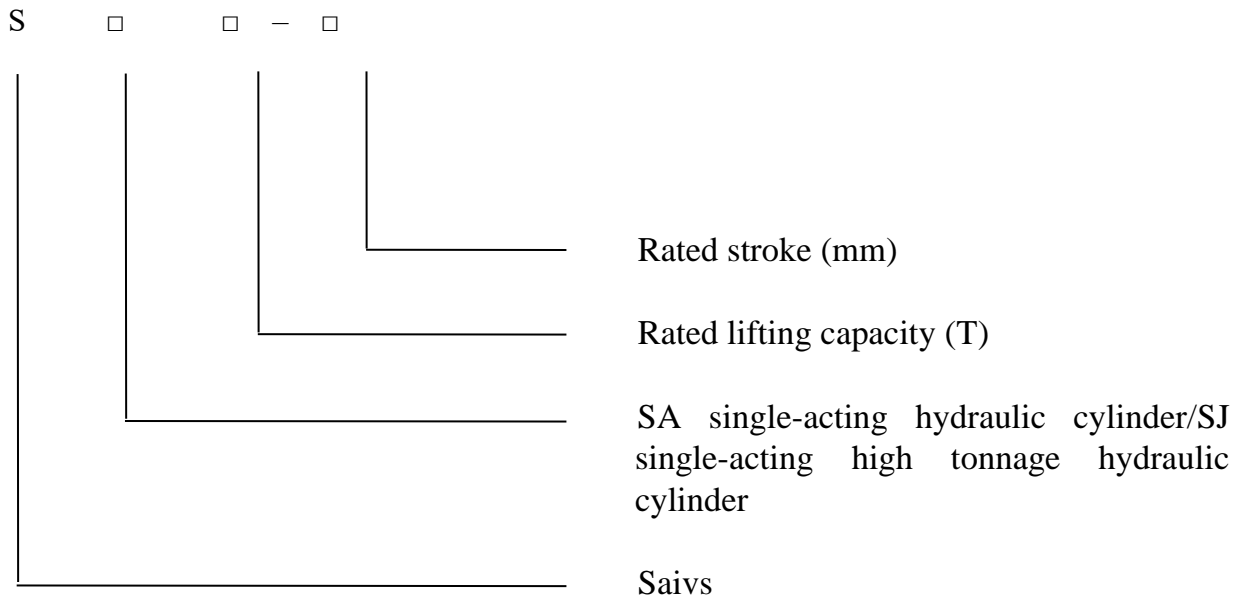

Saivs also provides the customization service for non-standard hydraulic cylinders at the customer's demands.

V. Technical Specification

RC Series

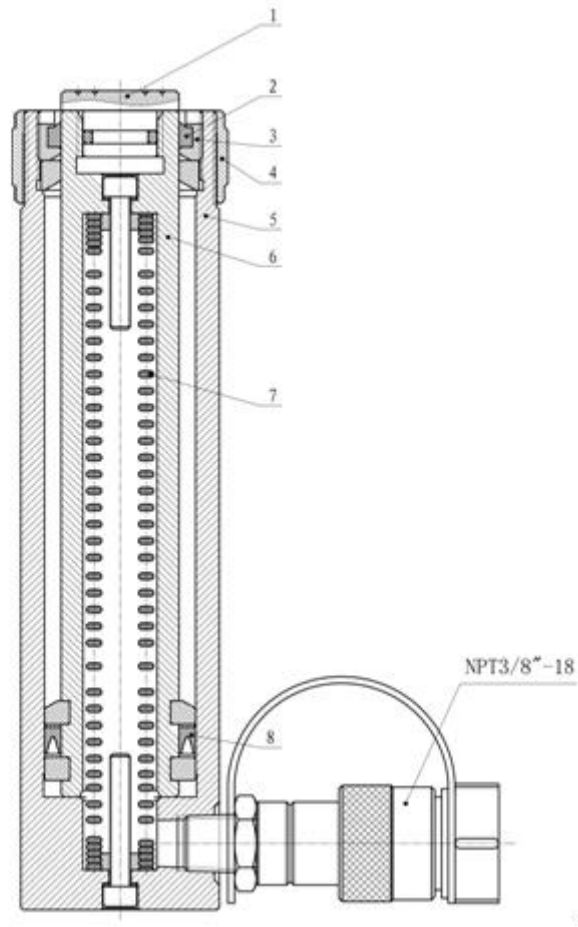

- 1 - Saddle 2 - Dust ring 3 - Guide cap 4 - Thread protective sleeve 5 - Cylinder
 6 - Piston rod 7 - Reset spring 8 - Seal ring 9 - Female connector

Model	Tonnage ton(KN)	Stroke (mm)	Hydraulic oil capacity (cm ³)	Body height	Extending height	Outside diameter	Cylinder bore diameter	Diameter of piston rod	Saddle diameter	Plunger female thread	Plunger thread length	Collar thread	Collar thread length	Weight (kg)
				A (mm)	B (mm)	C (mm)	D (mm)	E (mm)	H (mm)	K	L (mm)	X	Y (mm)	
RC5-25	5(45)	25	18	110	135	40	30	25	25	3/4"-16UN	14	1 1/2"-16	28	1
RC5-76		76	54	165	241	40	30	25	25	3/4"-16UN	14	1 1/2"-16	28	1.6
RC5-127		127	90	215	342	40	30	25	25	3/4"-16UN	14	1 1/2"-16	28	2
RC5-177		177	125	273	450	40	30	25	25	3/4"-16UN	14	1 1/2"-16	28	2.6
RC5-232		232	164	323	555	40	30	25	25	3/4"-16UN	14	1 1/2"-16	28	3.1
RC10-54	10(101)	54	86	121	175	59	45	35	35	1"-8UN	19	2 1/4"-14	28	2.3
RC10-105		105	167	171	276	59	45	35	35	1"-8UN	19	2 1/4"-14	28	3
RC10-156		156	248	247	403	59	45	35	35	1"-8UN	19	2 1/4"-14	28	4.1
RC10-203		203	323	298	501	59	45	35	35	1"-8UN	19	2 1/4"-14	28	5.8

RC10-257		257	409	349	606	59	45	35	35	1"-8UN	19	2 ³ / ₄ "-14	28	6.6
RC10-304		304	483	400	707	59	45	35	35	1"-8UN	19	2 ³ / ₄ "-14	28	7.5
RC10-356		356	566	450	806	59	45	35	35	1"-8UN	19	2 ³ / ₄ "-14	28	8.3
RC15-25	15(142)	25	53	124	149	70	52	42	38	1"-8UN	25	2 ³ / ₄ "-16	30	3.5
RC15-51		51	108	149	200	70	52	42	38	1"-8UN	25	2 ³ / ₄ "-16	30	4
RC15-101		101	214	200	301	70	52	42	38	1"-8UN	25	2 ³ / ₄ "-16	30	5
RC15-152		152	323	271	423	70	52	42	38	1"-8UN	25	2 ³ / ₄ "-16	30	7
RC15-203		203	431	322	525	70	52	42	38	1"-8UN	25	2 ³ / ₄ "-16	30	8
RC15-254		254	539	373	627	70	52	42	38	1"-8UN	25	2 ³ / ₄ "-16	30	9
RC15-305		305	647	423	728	70	52	42	38	1"-8UN	25	2 ³ / ₄ "-16	30	10
RC15-356		356	756	474	830	70	52	42	38	1"-8UN	25	2 ³ / ₄ "-16	30	11
RC25-26		25(232)	26	86	139	165	85	65	56	50	1 ¹ / ₂ "-16UN	25	3 ⁵ / ₁₆ "-12	49
RC25-50	50		166	165	215	85	65	56	50	1 ¹ / ₂ "-16UN	25	3 ⁵ / ₁₆ "-12	49	7
RC25-102	102		338	215	317	85	65	56	50	1 ¹ / ₂ "-16UN	25	3 ⁵ / ₁₆ "-12	49	8
RC25-158	158		524	273	431	85	65	56	50	1 ¹ / ₂ "-16UN	25	3 ⁵ / ₁₆ "-12	49	10
RC25-210	210		696	323	533	85	65	56	50	1 ¹ / ₂ "-16UN	25	3 ⁵ / ₁₆ "-12	49	12
RC25-261	261		866	374	635	85	65	56	50	1 ¹ / ₂ "-16UN	25	3 ⁵ / ₁₆ "-12	49	14
RC25-311	311		1031	425	736	85	65	56	50	1 ¹ / ₂ "-16UN	25	3 ⁵ / ₁₆ "-12	49	15
RC25-362	362		1201	476	838	85	65	56	50	1 ¹ / ₂ "-16UN	25	3 ⁵ / ₁₆ "-12	49	17
RC30-50	30(295)	50	209	228	278	101	73	60	50	1 ¹ / ₂ "-16UN	25	3 ⁷ / ₈ "-12	49	13
RC30-100		100	418	278	378	101	73	60	50	1 ¹ / ₂ "-16UN	25	3 ⁷ / ₈ "-12	49	16
RC30-209		209	874	387	596	101	73	60	50	1 ¹ / ₂ "-16UN	25	3 ⁷ / ₈ "-12	49	19
RC30-300		300	1255	478	778	101	73	60	50	1 ¹ / ₂ "-16UN	25	3 ⁷ / ₈ "-12	49	27
RC50-51	50(498)	51	361	176	227	127	95	80	\	\	\	5"-12	55	15
RC50-101		101	716	227	328	127	95	80	\	\	\	5"-12	55	19
RC50-159		159	1126	282	441	127	95	80	\	\	\	5"-12	55	23
RC50-337		337	2388	460	797	127	95	80	\	\	\	5"-12	55	37
RC75-156	75(718)	156	1620	285	441	150	115	100	\	\	\	5 ³ / ₄ "-12	44	33
RC75-333		333	3457	492	825	150	115	100	\	\	\	5 ³ / ₄ "-12	44	54
RC100-168	100(933)	168	2229	357	525	177	130	112	\	\	\	6 ⁷ / ₈ "-12	44	59
RC100-260		260	3449	449	709	177	130	112	\	\	\	6 ⁷ / ₈ "-12	44	72

The parameters listed in the table may be subject to change due to improvement without further notice.

HCG Series

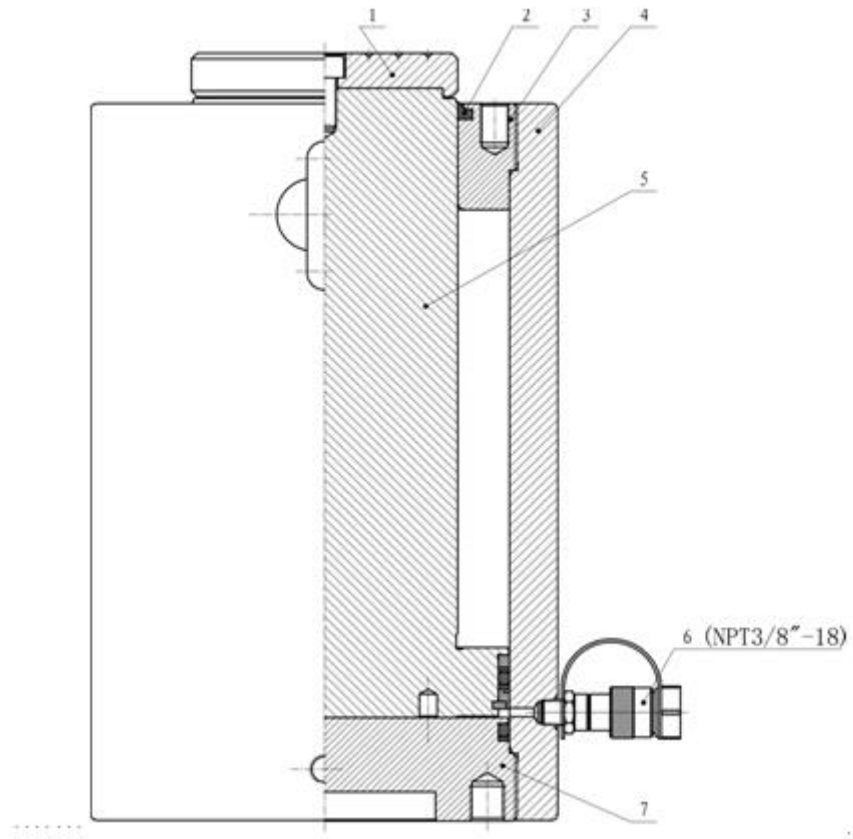

- 1 - Saddle 2 - Dust ring 3 - Guide cap 4 - Cylinder 5 - Piston rod
6 - Quick Coupling (Female) 7-Base

Model	Tonnage	Stroke (mm)	Hydraulic oil capacity (cm ³)	Body height	Extending height	Outside diameter (mm)	Cylinder bore diameter (mm)	Diameter of piston rod (mm)	Saddle diameter (mm)	Weight (kg)
	ton			A (mm)	B (mm)					
HCG50-50	50	50	392	188	238	140	100	70	70	21.5
HCG50-100		100	784	238	338	140	100	70	70	26
HCG50-150		150	1176	288	438	140	100	70	70	31
HCG50-200		200	1568	338	538	140	100	70	70	35
HCG50-300		300	2352	438	738	140	100	70	70	44
HCG100-50	100	50	770	216	266	188	140	100	100	42
HCG100-100		100	1540	266	366	188	140	100	100	49
HCG100-150		150	2310	316	466	188	140	100	100	56

HCG100-200		200	3080	366	566	188	140	100	100	63
HCG100-300		300	4620	466	766	188	140	100	100	70
HCG150-50	150	50	1005	224	274	215	165	120	120	44
HCG150-100		100	2010	274	374	215	165	120	120	57
HCG150-150		150	3015	324	474	215	165	120	120	70
HCG150-200		200	4020	374	574	215	165	120	120	83
HCG150-300		300	6030	474	774	215	165	120	120	109
HCG200-50	200	50	1570	246	296	268	200	150	150	84
HCG200-150		150	4712	346	496	268	200	150	150	118
HCG200-300		300	9423	496	796	268	200	150	150	152
HCG300-50	320	50	2453	277	327	320	245	180	180	155
HCG300-150		150	7359	377	527	320	245	180	180	195
HCG300-300		300	14718	527	827	320	245	180	180	255
HCG400-50	400	50	2861	305	355	350	270	200	216	240
HCG400-150		150	8583	405	555	350	270	200	216	310
HCG400-300		300	17169	555	855	350	270	200	216	415
HCG500-50	500	50	4019	325	375	395	305	250	246	285
HCG500-150		150	12057	425	575	395	305	250	246	353
HCG500-300		300	24114	575	875	395	305	250	246	455
HCG600-50	630	50	5087	386	436	430	340	280	270	487
HCG600-150		150	15261	486	636	430	340	280	270	579
HCG600-300		300	30522	636	936	430	340	280	270	717
HCG800-50	800	50	6280	427	477	550	400	320	320	712
HCG800-150		150	18840	527	677	550	400	320	320	860
HCG800-300		300	37698	677	977	550	400	320	320	1082

The parameters listed in the table may be subject to change due to improvement without further notice.

VI. Operation Method

1. Before operations, ensure to check all parts for normal functioning.
2. During operations, strictly abide by the requirements specified in the main specification and eliminate the over-height and overload to prevent accidents.
3. If a hand pump is used as the power source, connect the cylinder, oil hoses, and hand pump by quick couplings, as shown in Figure (I) below.

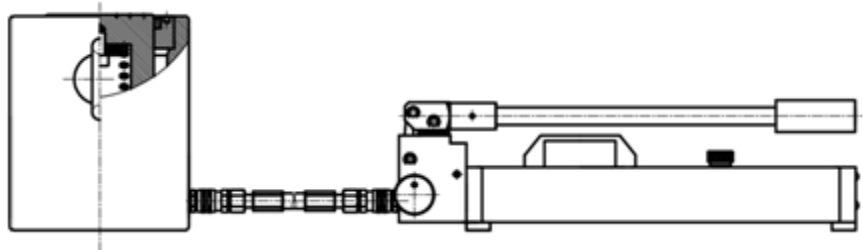

Figure (I)

4. If a super-pressure electric pump is used as the power source, connect the cylinder, oil hoses, and electric pump by quick couplings, as shown in Figure (II) below.

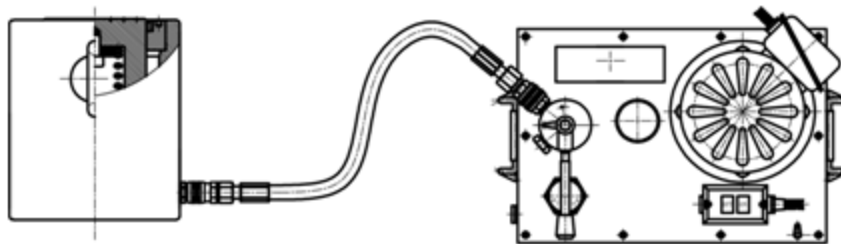

Figure (II)

5. The connection method for quick couplings is shown in figure (III) below: Directly connect the male connector with the female connector axially to the end and then tighten the sleeve. To detach the quick coupling, unscrew the sleeve, pull out the female (male) connector axially, and install the dust caps.

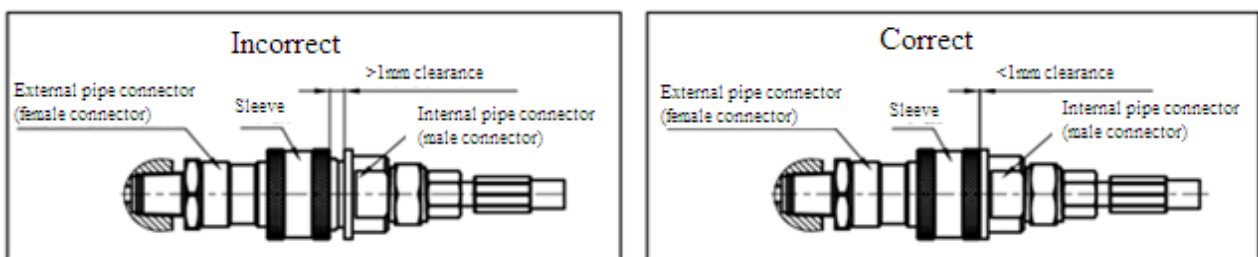

Figure (III)



Warning: Ensure the complete engagement while connecting the quick coupling, in order to ensure that the check valve in the connector is opened to prevent oil line blockage. Otherwise, the check valve in the connected coupling can't open to cause obstructed oil line.



Notice: Ensure to apply the force axially during the disassembling and assembling, in order to prevent damaging O-rings or blocking the external hose connectors.



Notice: Keep clean the quick coupling against the ingress of impurities into pipeline, otherwise it will lead to pipeline leakage or blockage.



Notice: Do not loosen any high pressure oil hose during the operating.

6. Determine the gravity center for the load. Appropriately select the support point of the cylinder and cushion its bottom face levelly and stably to prevent sinkage and inclination (The hardness of the ground shall be taken into consideration to determine the necessity of cushioning with tough wood boards).

7. Firstly perform the no-load running:

Hand pump: Tighten the hand wheel clockwise on the unloading valve of the hand pump and lift and depress the handle on the hand pump to lift the piston rod. When the piston rod lifts to the rated stroke of the cylinder, loosen counter-clockwise the hand wheel on unloading valve so that the piston rod returns under the action of reset spring (under action of gravity for HCG series). Repeat above operation for several times. If no abnormality is detected, the cylinder can be used for lifting of weights. (Please refer to the corresponding operation manual for the operations of hand pump)

Electric pump: Start the electric pump and operate the handle of reversing valve on the electric pump to the working position connected to the oil hose to lift the piston rod. When the piston rod lifts to the rated stroke of the cylinder, operate the handle to the neutral unloading position so that the piston rod returns under the action of reset spring (under action of gravity for HCG series). Repeat above operation for several times. If no abnormality is detected, the cylinder can be used for lifting of weights. (Please refer to the corresponding operation instructions for the operations of electric pump)

8. Preparations: When the piston rod lifts a weight to the required stroke, immediately support the weight securely by supports and never use the cylinder as support. If the long-term support of

the weight by the cylinder is required, please select SSL or SJL series mechanical self-locking hydraulic cylinder manufactured by our company.

9. Completion: Operate the directional control valve of electric pump to neutral position, timely cut off the power supply, and disassemble the high pressure hoses and install the dust caps.

VII. Troubleshooting

Problem	Possible malfunction cause
Cylinder will not advance	Opened relief valve of pump
	Incompletely tightened connectors
	Low oil level in pump
	Pump malfunction
	Load beyond carrying capacity of cylinder
	Leakage of cylinder seals
Cylinder only advances for one segment	Low oil level in pump
	Incompletely tightened connectors
	Obstructed motion of cylinder piston
Sudden advancement of cylinder	Air content in hydraulic system
	Obstructed motion of cylinder piston
Low advancement speed of cylinder	Connection leakage
	Incompletely tightened connectors
	Pump malfunction
Cylinder could advance but can not hold the pressure	Pump malfunction
	Connection leakage
	Incorrect system settings
	Leakage of cylinder seals
Oil leakage of cylinder.	Wear or damage of seals
	Internal damage of cylinder
	Loose connection
Reversing failure or slow reversing speed of cylinder	Incompletely tightened connectors
	Excessive oil in pump oil tank
	Obstructed flow due to undersized hose
	Damage or insufficient elasticity of compression spring (if equipped)
	Internal damage of cylinder
Oil leakage of external relief valve	Incompletely tightened connectors
	Obstructed oil return pipeline

Note:

- 1. Our company reserves the modification right for these operation instructions of this hydraulic cylinder without further notice.**
- 2. For more detailed information, please contact our company.**

Ningbo Saivs Machinery Co., Ltd.

Postal code: 315135

Tel.: +86-574-88067629

+86-574-88344911

Fax: +86-574-88345368

Website: www.saivs-industrial.com

www.saivstool.com

